



FM 464

Avery Dennison FM 464 is a 920 µm black foam tape with double coated pure acrylic adhesive on both sides. It has good tack and very high shear properties. FM 464 is suitable for badge and emblem mounting in automobiles.

FEATURES:

- Double coated polyethylene foam carrier
- Pure acrylic adhesive skin
- Polyethylene protected paper liner

BENEFITS:

- Proven performance through multiple years of use
- Easy to die-cut properties allow for even small die-cut pieces

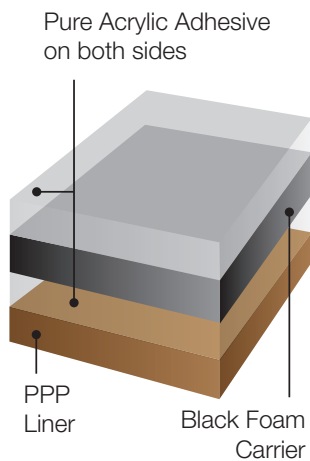

CONSTRUCTION:

Adhesive:

Pure acrylic adhesive

Carrier:

Black closed cell polyethylene foam

Liner:

Brown polyethylene protected paper

FM 464

Physical Properties	Typical Values	
THICKNESS:		
Adhesive + Foam	920 µm	
Liner	130 µm	
Total	1,050 µm	
FOAM DENSITY:		
	143 kg/m ³	
PEEL ADHESION:		
90° peel - 2 kg - 24 RT dwell - 300mm/min	Automotive MSE Clear Coat	Automotive LSE Clear Coat
125µ aluminum reinforcement	10 N/cm	5 N/cm
DYNAMIC SHEAR:		
5 kg - 24 hr RT dwell - 12,7mm/min	Automotive MSE Clear Coat	
Stainless Steel	600 kPa	
STATIC SHEAR:		
5 kg - 24hr RT dwell	Automotive MSE Clear Coat	
Stainless Steel 6.45 cm ² - 1000g - RT	>10,000 mins	
Stainless Steel 6.45 cm ² - 500g - 80°C	>10,000 mins	
PLUCK ADHESION:		
Aluminum	Automotive MSE Clear Coat	
1inch ² overlap - 5 kg - 24 hr dwell - 25.4 mm	600 kPa	
TEMPERATURES:		
Long Term (6,45cm ² - 500g - 10,000 mins)	90°C / 194°F	
Short term (1cm ² - 100g - 240 mins)	105°C / 221°F	
*ASTM D3654		
*MSE - Medium Surface Energy		

Note: The listed values are typical only and not intended to serve as product specifications

APPLICATION TECHNIQUES

- It is essential with all pressure-sensitive tapes the application surface is clean, dry and free of grease and oil
- Bond strength is dependent upon the amount of adhesive-to-surface contact developed
- Note that different pressure, time and temperature on different (firm / rigid) surface achieves different performance

STORAGE AND SHELF LIFE

The shelf life of the product is two year when stored at 18-22°C / 64-72°F, 30-70% relative humidity and out of direct sunlight, in original packaging.

Warranty and Disclaimer: All statements, technical information and recommendations about AVERY DENNISON products are based upon tests believed to be reliable but do not constitute a guarantee or warranty. All AVERY DENNISON products are sold with the understanding that PURCHASER has independently determined the suitability of such products for its purposes. AVERY DENNISON products are warranted to the original purchaser to be free from defects in material or workmanship for a period of one year from date of shipment. Purchaser's sole and exclusive remedy for breach of this warranty shall be the replacement of the defective products or, at AVERY DENNISON's option, the issuance of a credit or refund in an amount up to the purchase price of the defective product. In no event shall AVERY DENNISON be responsible for claims beyond the purchase price of the defective product.

THE WARRANTY SPECIFICALLY SET FORTH ABOVE IS IN LIEU OF ANY OTHER WARRANTIES, EXPRESS OR IMPLIED, INCLUDING, BUT NOT LIMITED TO, ANY IMPLIED WARRANTIES OF MERCHANTABILITY, FITNESS FOR ANY PARTICULAR USE AND/OR NON-INFRINGEMENT. AVERY DENNISON SPECIFICALLY DISCLAIMS AND EXCLUDES ALL OTHER SUCH WARRANTIES. IN NO EVENT SHALL AVERY DENNISON BE LIABLE TO PURCHASER OR ANY OTHER PARTY FOR INDIRECT, CONSEQUENTIAL, INCIDENTAL, SPECIAL OR PUNITIVE DAMAGES.

No representative, or agent of AVERY DENNISON is authorized to give any guarantee or warranty or make any representation contrary to the above. No waiver, alteration, addition or modification of the foregoing conditions shall be valid unless made in writing and signed by an executive officer of AVERY DENNISON.

© 2012 Avery Dennison Corporation. All rights reserved. Avery Dennison® is a registered trademark of Avery Dennison Corporation. Avery™, AFB™ and all other Avery Dennison brands, product names, antenna designs and codes or service programs are trademarks of Avery Dennison Corporation.



Performance
Tapes

Asia Pacific

Kunshan, China,
NO. 618 Nanhe Road
Kunshan Economic &
Technological Zone
China 215335
Phone: +86 512 57155001
Fax: +86 512 57155059
www.stap.averydennison.com

Europe

Tieblokkenlaan 1
B-2300 Turnhout
Belgium
Phone: +32 (0)14 40 48 11
Fax: +32 (0)14 40 48 55
www.steu.averydennison.com

South America

Rua Francisco Foga, 225
13280-000 Vinhedo
SP Brazil
Phone: +55 19 3876 7736
Fax: +55 19 3876 7682

North America

250 Chester Street
Painesville, Ohio
44077 USA
Phone: +1 866-462-8379
Fax: +1 888-358-4469
www.stus.averydennison.com